

### Loop Power, 4-20 mA Output Vibration Sensors

The purpose of the 4-20 mA analog current loop is to transmit the signal from an analog vibration sensor over a distance in the form of a current signal. PRO's loop power sensors output a 4-20 mA current that is proportional to the overall vibration of the equipment or machinery they are monitoring. This output current has a range of 4-20 mA (4 mA normally representing the sensor's zero-level output, and 20 mA representing the sensor's full-scale output).

Only two wires are required to send the current signal and also supply power to the sensor. A loop supply voltage is used to power the remote sensor. The remote sensor regulates the loop current such that the loop current represents the value of the parameter being measured by the sensor. A series resistor  $R_L$  at the loop power supply converts this current to a voltage that can be used by the process monitor/controller to record or distribute the parameter being measured.

### Typical Loop Powered Circuit

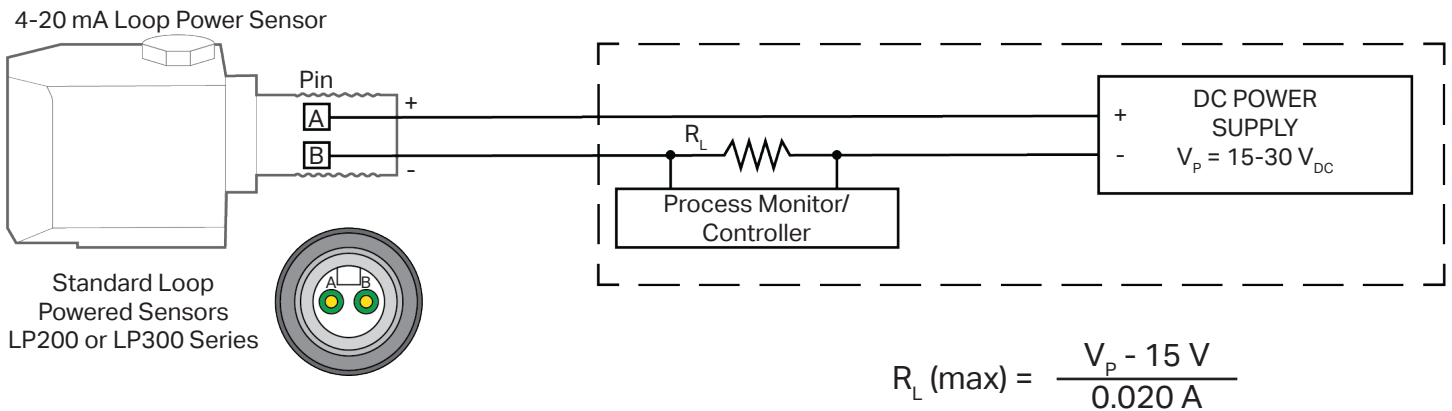

### Loop Resistance Calculations

**Standard Loop Powered Sensors**

$$R_L (\text{max}) = \frac{V_p - 15 \text{ V} \times (1 \text{ mA} / .001 \text{ A})}{20 \text{ mA}}$$

**\*Intrinsically Safe Loop Powered Sensors**

$$R_L (\text{max}) = \frac{V_p - 12 \text{ V} \times (1 \text{ mA} / .001 \text{ A})}{20 \text{ mA}}$$

\*Note: Typical Loop Powered Circuit will include an IS Barrier in the Circuit

Power Source Voltage ( $V_p$ )	Typical $R_L$ (max) (Non-IS Sensors)	Typical $R_L$ (max) (IS Sensors)
20	250	100
24	450	300
26	550	400
30	750	600